



Advanced Micro Lites, Inc.

205 Dempsey Street, Elburn, IL 60119

630-365-5450 tel

630-365-5456 fax

www.advmicrolites.com

L513KWWC

5mm Warm White LED Lamp

PACKAGE OUTLINES

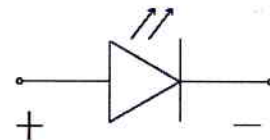
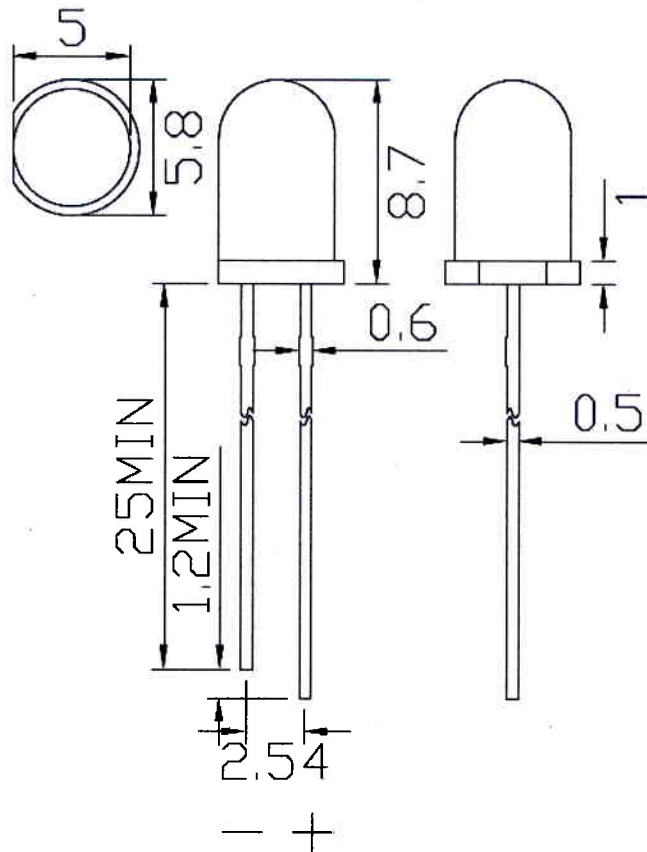

ITEM	MATERIALS
Dice	InGaN
Lens Color	Clear
Emitted Color	Warm White

Notes:

1. All dimensions are in millimeters (inches)
2. Tolerances are ± 0.15 mm unless otherwise noted.



Advanced Micro Lites, Inc.

205 Dempsey Street, Elburn, IL 60119
630-365-5450 tel
630-365-5456 fax
www.advmicrolites.com

L513KWWC 5mm Warm White LED Lamp

ABSOLUTE MAXIMUM RATINGS

(Ta = 25°C)

Parameter	Symbol	Value	Unit
Power Dissipation	P _D	100	mW
Forward Current	I _F	30	mA
Peak Forward Current (1/10 duty, cycle: 0.1ms Pulse Width)	I _{PF}	60	mA
Reverse Voltage	V _R	5	V
Operating Temperature Range	T _{OPR}	-25 ~ +85	°C
Storage Humidity	T _{SH}	45% ~ 85%	°F
Storage Temperature Range	T _{STG}	-30 ~ +85	°C
Soldering Temperature	T _{SOL}	260°C for 5 seconds	

OPTICAL-ELECTRICAL CHARACTERISTICS

(Ta = 25°C)

Parameter	Symbol	Test Condition	Value			Unit
			Min	Typ	Max	
Luminous Intensity	I _V	I _F =20mA	15000	--	20000	mcd
Forward Voltage	V _F	I _F =20mA	3.0	--	3.4	V
Suggested Forward Current	I _F	--	3	15	20	mA
Reverse current	I _R	V _R =5V	--	--	5	µA
Correlated Color Temperature	CCT	I _F =20mA	3000	--	3500	K
Chromatic Coordinates	X	I _F =20mA	--	0.42	--	--
	Y		--	0.40	--	
Viewing Angle	2θ½	I _F =20mA	--	15	--	deg

When using LEDs in circuits, it is recommended to limit the forward current to 5~10 mA, ≤20 mA.



Advanced Micro Lites, Inc.

205 Dempsey Street, Elburn, IL 60119
630-365-5450 tel
630-365-5456 fax
www.advmicrolites.com

L513KWWC

5mm Warm White LED Lamp

OPTICAL CHARACTERISTIC CURVES

Forward Current vs. Forward Voltage

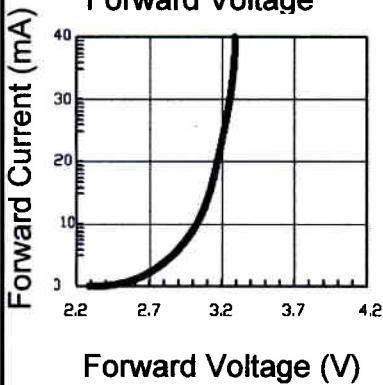

Forward Current vs. Relative Luminous Intensity

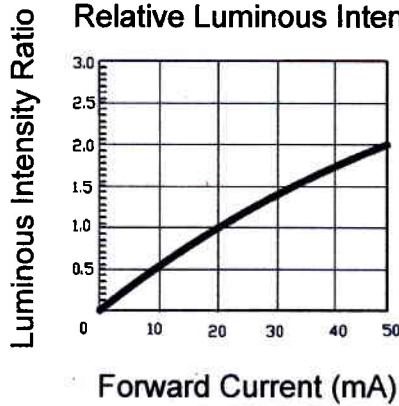

Forward Current vs. Ambient Temperature

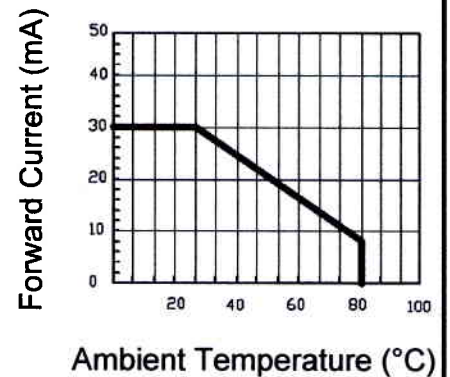

Relative Luminous Intensity vs. Ambient Temperature

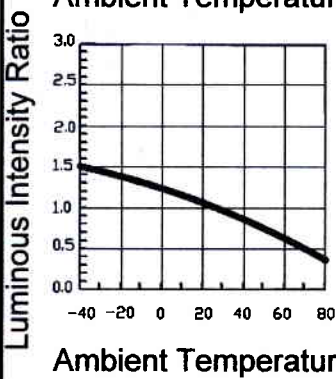

Relative Luminous Intensity vs. Main Wavelength

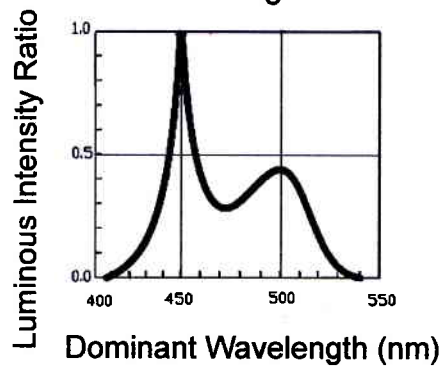

Radiation Diagram

